

USER MANUAL

P100

Touch Key
Stand Alone Access Controller
13.56 MHZ Card Reader

DELTONS

1. Specification

1.1 Technical Parameters :

NO	ITEM	VALUE
1	Operating voltage	DC 12V10%
2	Operating current	< 100mA
3	Dimensons	120x78x22(mm)
4	Weight	110g
5	Ambient temperature	0C-60C
6	Relative humidity	20%-80%
7	Storage	1000users
8	Card type	Mifare 13.56MHz Card
9	Card reading distance	1-15cm

1.2 Technical Parameters :

Programming Password	123456
Common Access Password	None
Relay Unlock output	5 Seconds
Open mode	Card or Access Password Access Password include Private Access Password (PIN) and common access password
Security mode	OFF
Backlight (For options)	Auto
W26 port (For options)	Input

1.3 Light and Sound indicates :

Light : Red and Green

Light Description	Indicates
Red light flash every 1 sec (Slow flash)	Standby state
Green light flash every 0,5sec (Fast flash)	Pending further action
Red light is always ON	Programming state
Green light is always ON within Open Time	Unlocking state

Sound : Buzz

Sound Description	Indicates
1 short buzz	Valid input
3 short buzz	Invalid input
1 long buzz	Programming success
Continuous long buzz	Restoring factory programming passwords

2. Installation Guide

JP 1 Terminal

No	Mark	Color	Function
1	+12V	Red	Power+
2	GND	Black	Power-
3	PUSH	BLUE	Low level output
4	OPEN	yellow	Door Release
5	BEL+	Grey	Hight level Input
6	BEL-	White	Voltage Output

JP 2 Terminal

No	Mark	Color	Function
1	+12v	Red	Power+
2	GND	Black	Power-
3	DATA0	Green	WG DATA0
4	DATA1	White	WG DATA1
5	NC	Brown	Relay NC output
6	COM	Blue	Relay Com output
7	NO	Purple	Relay NO output

Wiring Diagram

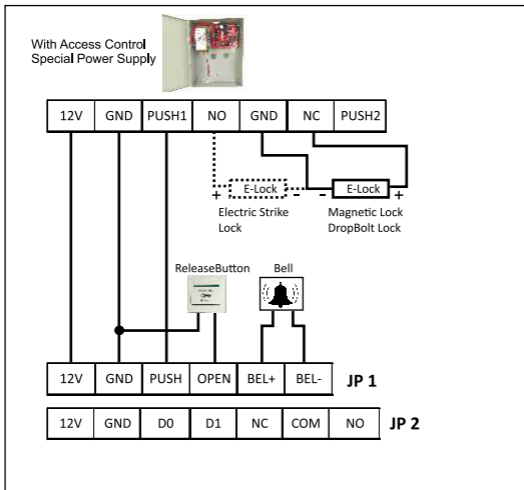



With Common
Adaptor Power Supply

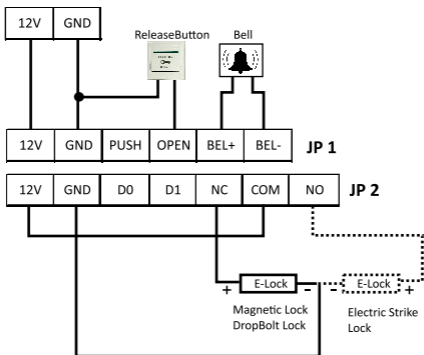

Wiegand Output Reader

This Unit support Wiegand 26 bit Output, so the Wiegand data lines can be connected to any controller which support Wiegand 26 bit input.

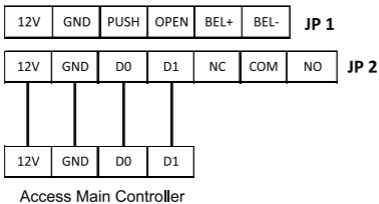

3. Programmin Guide

3.1 Detail Function

Program Code Default : 123456. Password can be 3-6 digits.

Purpose	Operations
Change Program Code	# Program Code # 0 new Code # new Code# <i>If Program Code lost, perform 3.2 to reset to Factory Default (123456)</i>
Add user card	# Program Code # 1 read card # <i>If add multi cards, read cards continuously</i>
Set Public Password	# Program Code # 21 new Public Password <i>Public Password is only one. Open method: Input Public Password #</i>
Delete all users	# Program Code # 40 0000 # <i>Delete all cards and PIN except Public Password</i>
Delete user by read card	# Program Code # 41 read card # <i>If delete multi cards, read cards continuously</i>
Add Private Access Password(PIN)	# Program Code # 22 PIN # <i>PIN can be more. Open method: PIN #</i>
Add card by input card No.	# Program Code # 23 input card No. # <i>Card No. is 10-digit or 8-digit, machine auto-indentify</i>
Add multi-card by input card No. zone	# Program Code # 24 input start card No. Card Qty # <i>Card Qty is 4-digit (If one-time add twenty cards, input 0020)</i>
Add "card +PIN"	# Program Code # 3 read card PIN # <i>If modify PIN, see 3.5</i>
Delete user by input User ID No.	# Program Code # 42 INPUT User ID No. # <i>About User ID NO. see 3.4</i>
Delete user by input card No.	# Program Code # 43 input card No. #Card <i>No. is 10-digit or 8-digit, machine auto-indentify</i>

Delete user by input PIN	# Program Code # 44 input PIN # <i>PIN IS 3-6 digits.</i>
Delete all PIN users	# Program Code # 45 1111 # <i>Use for PIN users (Do not include Card users and Card +PIN users)</i>
Change Open time	# Program Code # 5 XX # <i>XX can be 2-digit, and the max. is 99. If input 00, the signal output time is 0.2 Secs.</i>
Set Open mode	# Program Code # 6 XX # <i>XX can be 01(only Card) / 02 (Card or Access Password) / 03 (Card=PIN)</i>
Reader setting (For options)	# Program Code # 6 04 # <i>The machine can be used for reader(W26 output)</i>
Security function setting Anti-dismantle alarm setting(For options)	# Program Code # 7 XX # <i>XX can be 01/02(security function OFF / ON) and 03/04(Anti-dismantle Alarm OFF / ON) Remark: Security Function ON means System would be locked for 5 Minutes if countinue to read illegal cards or input wrong Access Password for 10 tomes.</i>
Backlight setting (For options)	# Program Code # 8 xx # <i>XX can be 01/02/03 (Normal ON / Normal OFF / Auto)</i>
Reset Factory Default	# Program Code # 8 99 # <i>Except Program Code and Manager Card</i>
Set Manager Card	# Program Code # 91 read MDC # <i>First read card is Manager Add Card and Second read card is Manager Delete Card.</i>
Cancel Manager Card	# Program Code # 92 # <i>MAC: Manager Add CARD, MDC: Manager Delete Card</i>

3.2 Reset to Factory Program Code (Default 123456)

Step1 Turn off power and connect bin 2&3 of RST(S1)

Step2 Turn on power and buzzer gives 3 long buzz with green light flash fast.

If need to set Manager Card, now read two empty cards first one as Manager Add Card and Second one as Manager Delete Card with red light flashing and continuous short buzz

Step3 Turn off power, disconnect bin2&3 and connect bin 1&2 of RST

Step4 Turn on power again

3.3 How to use Manager Card – MAC&MDC

To add a card user in standby mode: read MAC read new cards read MAC

To delete a card user in standby mode: read MDC read registered cards
Read MDC

To delete all users in standby mode: read MDC READ MAC READ MDC

Remark: User cards can be added or deleted continuously

3.4 User ID No. explain

User ID IS AUTO-GENERATING 4-DIGIT NUMBER STARTED AT 0001. The number Increases with adding user one and ignores deleting user.

Common Access Password has no ID.

3.5 How to change PIN (When open mode: card+ PIN)

After reading card and input corresponding PIN to open the door,

Within 5 seconds, long press # until the green light flash fast, and

Then input new PIN # new PIN #, new PIN changed successfully

With a long buzz

The logo for DELTONS is displayed in white, uppercase letters within a dark grey rounded rectangular background. The letters are bold and have a modern, sans-serif font style.