

DELTONS

Instruction of smart lock

DX4

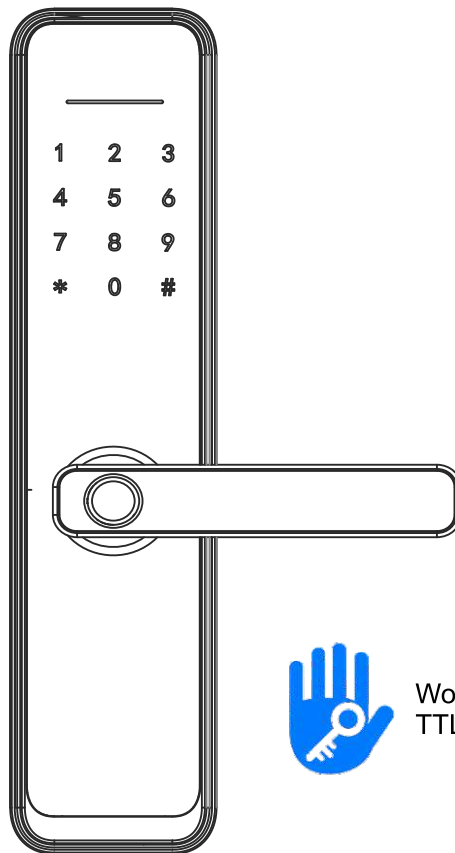

Work with
TTLock APP

NOTICE:

1. Please read this instruction sheet before used.
2. Please take key with you or put it outside the room.



INFORMATION AND SAFTY WARNINGS :

Introduction:

This user manual will guide you through the functions and usages of our DX4 Bluetooth enabled smart lock. It is important that you follow the instructions and regard all notes that appear throughout this manual. Consult this manual before you attempt to use the lock. If you have questions not answered by this manual or are in need of non-routine service, contact our customer service (Phone Number)



Safety Warnings:

When reading this manual, note these icons: notes with this icon **MUST be read, understood and obeyed to prevent injury or damage.**

General Usage



- This lock shall only be used as described in this manual.
- Verify that all parts of the lock are account for. If any parts are missing, contact our customer service.
- In factory default status, the lock is on always open state after you install the lock (no power on). It means handle is free and lock can't be closed, you have to power on the lock with batteries or set admin and pair the lock with app and then the open mode will be changed to private mode automatically.
- Handle directions are reversible, please kindly follow chapter 4 (installation steps3) to change the direction. Should you have any problem, please contact our customer service.
- There is a protective film on the front touch panel, if there are some scratches on the film, don't be scared. The protective film can be removed if you need.
- Use only four AA batteries. Do not mix old and new batteries or batteries from different brands. Never insert objects into the lock other than batteries as described in this manual.
- Verify all surfaces are flat and level before beginning installation, installation on doors or surface with any types of deformity such as gaps or warping may cause the lock to malfunction or fail to operate entirely.
- Never apply any cleaner directly to any part of the lock. Only use clean water and mild cleaner on a soft non-abrasive cloth when cleaning.
- Potential shock warning: do not allow water or liquids to get into lock's electric parts.
- The lock must be used with TT lock app. The lock will function without the app but full functionality may only be achieved when the app is used.

1. installation

- a. Professional installation recommended
- b. Pay attention to the connecting cable during installation.
- c. Please adjust the handle direction according to the instructions.
- d. It is necessary to keep the door half open during installation
- e. After installation, please check whether fingerprint, password, IC card, key, internal and external handle, and anti lock switch can work normally.
- f. If it can't be used normally check for improper installation.

2. Installation diagram

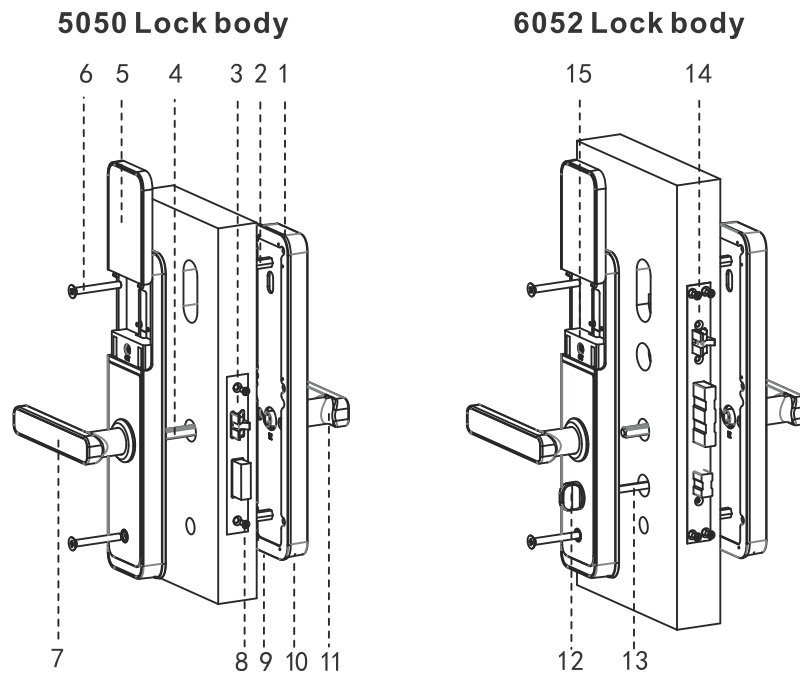

- | | | |
|--------------------------------|---------------------------|-----------------------|
| 1. Outer panel | 2. Connecting column | 3. lock body |
| 4. Square bar | 5. Battery case cover | 6. Connecting screw |
| 7. Back handle | 8. Lock body fixing screw | |
| 9. Emergency power supply port | 10. Lock core | |
| 11. Front handle | 12. knob | 13. Anti lock pick up |
| 15. Setting key | | 14. Lock body(6052) |

3. Confirm the direction of the handle

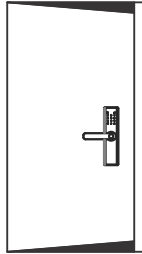

Left door opening

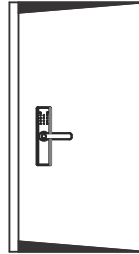

Right door opening

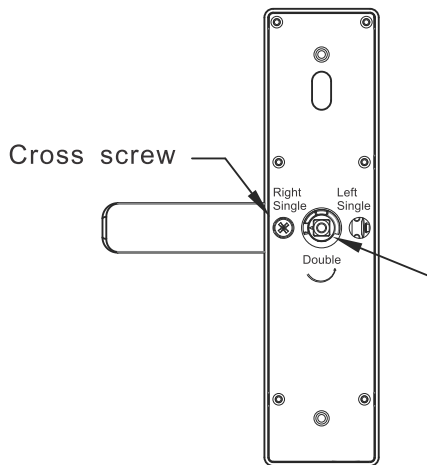

Change direction of the handle
1. Remove the cross screw in the figure, Turn the handle 180 degrees in the direction of the arrow.
2. After adjusting the handle direction, install the screw and complete the reversing.

Attention: hexagon socket screw is fixed when changing the handle direction.

4. Cutout

Refer to the hole drawing and the lock body model.

5. Install the lock body:

- 5.1 Support lock body model: 5050,4585,6085,5572,6072, 6052,ball lock, etc.
- 5.2 Adjust the direction of the diagonal tongue according to the direction of the door.

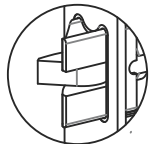

Left inside open
Right outside open

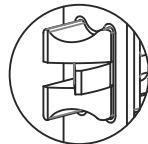

Right inside open
Left outside open

5.3 Lock body reversing

5050 lock body

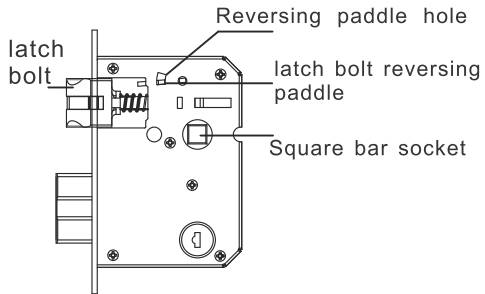

5572 lock body

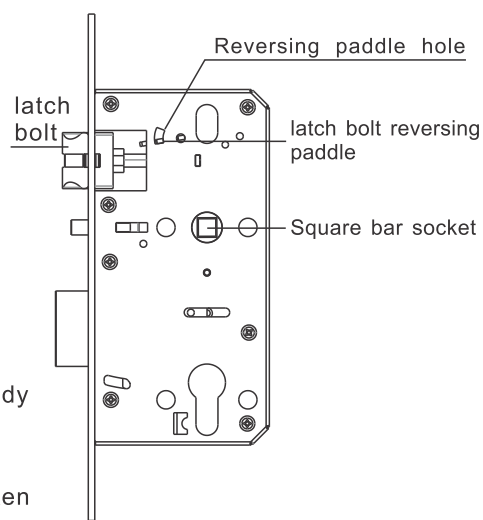

- Pull the reversing paddle of locking tab to the other end.
- Push the oblique tongue into the lock body and rotate 180 degrees.
- Release reversing paddle.
- Install the lock into the door frame. Tighten the fixing screw of lock body.

6. Door lock installation

6.1 Connect the two corresponding studs on the outer plate

6.2 Fixed outer panel

- Insert the square bar into the square bar hole
- Pull the main board connecting cable into the door
- Align the outer panel with the opening position and install the square bar

6.3 Fixed inner panel

- Connect the main board connecting cable, and put the redundant cable into the slot.
- Insert the anti lock paddle. The length of the paddle can be cut according to the thickness of the door (6052 lock body only).
- Align the square bar of the inner panel and compress the inner panel.
- Lock the screws and fix the panel.

7. Install the door buckle plate and buckle box

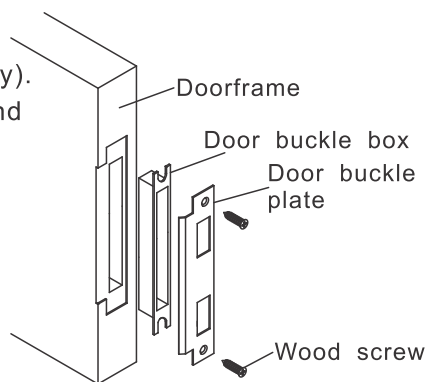

OPERATION FOR TTLOCK

Search on APP store or Android store or scan the QR code we provided to download TTLOCK and install it.

Please read this manual carefully before install and keep it properly. Please refer to sales agents and professionals for information not included in this manual.



Introduction

The App is a smart lock management software developed by Hangzhou Sciener Intelligent Control Technology Co.,Ltd. It includes door locks, parking locks, safe locks and more.

The App communicates with the lock via Bluetooth BLE and can unlock, lock, firmware upgrade, read operation records, etc. The Bluetooth key can also open the door lock through the watch.



The app supports Chinese, Traditional Chinese, English, Spanish, Portuguese, Russian, French and Malay.

Contents

1. Registration and login	4.4 Clear code
1.1 Security question settings	4.5 Cyclic passcode
1.2 Login authentication	4.6 Customized passcode
1.3 Ways of identifying	4.7 Passcode sharing
1.4 Login successful	4.8 Passcode management
2. Lock management	5. Card management
2.1 Lock adding	6. Fingerprint management
2.2 Lock upgrading	7. Unlock via Bluetooth
2.3 Error diagnosis and time calibration	8. Passage mode
2.4 Authorized administrator	9. Attendance management
3. Key management	9.1 Attendance setting
3.1 Key management	10. System setting
3.2 Deadline warning	10.1 User management
3.3 Search lock record	10.2 Group management settings
4. Passcode management	10.3 Transfer admin rights
4.1 Permanent passcode	10.4 Recycle bin
4.2 Time-limited passcode	10.5 Customer service
4.3 One-time passcode	10.6 About

1. Registration and login

Users can register the account by mobile phone and Email which currently support 200 countries and regions on the world. The verification code will be sent to user's mobile phone or email, and the registration will be successful after the verification.

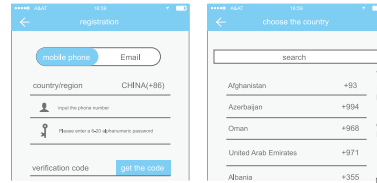

1.1 Security question settings

You will be taken to the security question settings page when registration is successful. When log in on a new device, the user can authenticate himself by answering the above questions.

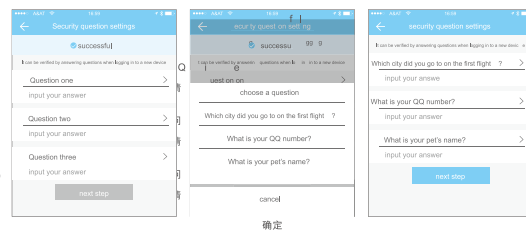

1.2 Login authentication

Log in with your mobile phone number or email account on the login page. The mobile phone number is automatically recognized by the system and does not input the country code.

If you have forgotten your password, you can go to the password reset page to reset your password. When reset the password, you can receive a verification code from your mobile phone and email address.

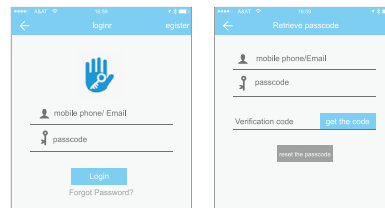

When the account is logged in on the new mobile phone, it needs to be verified. When it is passed, you can log in on the new mobile phone. All the data can be viewed and used on the new mobile phone.

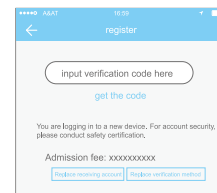

1.3 Ways of identifying

There are two ways of security verification. One is the way to get the verification code via the account number and the other is the way to answer the question.

If the current account is set the "answer the question" verification, then when the new device is logged in, there will be an "answer question verification" option.

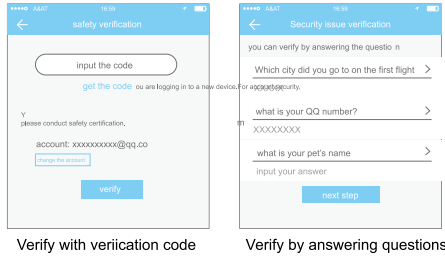

Verify with verification code

Verify by answering questions

1.4 Login successful

The first time you use the lock app, if there is no lock or key data in the account, the home page will display the button to add the lock. If there is already a lock or key in the account, the lock information will be displayed.

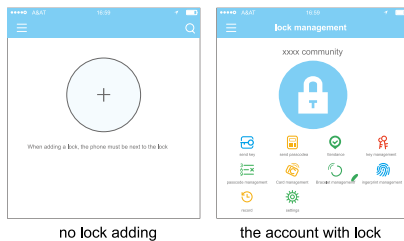

no lock adding

the account with lock

2. Lock management

The lock must be added on the app before it can be used. The addition of a lock refers to the initialization of the lock by communicating with the lock via Bluetooth. Please stand beside the lock. Once the lock is added successfully, you can manage the lock with the app including sending a key, sending a password, and so on.

When the lock is added, the adder becomes the administrator of the lock. At the same time, the lock cannot enter the setup mode by touching the keyboard. This lock can only be re-added after the current administrator has deleted the lock. The operation of deleting the lock needs to be done by Bluetooth beside the lock.

2.1 Lock adding

The App supports multiple types of lock, including door locks, padlocks, safe locks, smart lock cylinders, parking locks and bicycle locks. When adding a device, you must first select the lock type.

The lock needs to be added to the app after entering the setting mode. A lock that has not been added will enter the setting mode

as long as the lock keyboard is touched. The lock that has been added needs to be deleted on the App first.

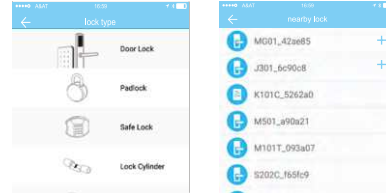

The initialization data of the lock needs to be uploaded to the network. The data needs to be uploaded when the network is available to complete the entire whole adding process.

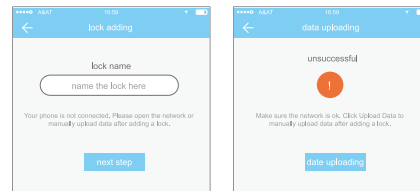

2.2 Lock upgrading

User can upgrade the lock hardware on the APP. The upgrade needs to be done via Bluetooth next to the lock. When the upgrade is successful, the original key, password, IC card and fingerprint can continue to be used.

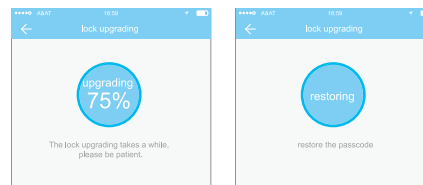

2.3 Error diagnosis and time calibration

Error diagnosis aims to help analyse the system problems. It needs to be done via Bluetooth beside the lock. If there is a gateway, the clock will be calibrated first through the gateway.

If there is no gateway, it needs to be calibrated by the mobile phone Bluetooth.

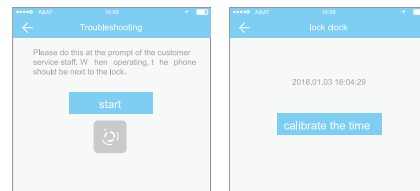

2.4 Authorized administrator

Only the administrator can authorize the key. When the authorization is successful, the authorized key is consistent with the administrator's interface. He can send keys to others, send passwords and more.

However, the authorized administrator can no longer authorize others.

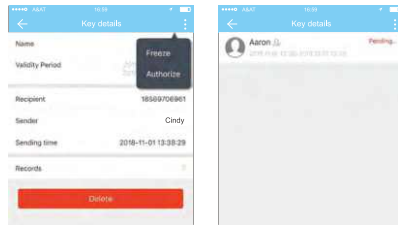

3. Key management

After the administrator successfully adds the lock, he owns the highest administrative rights to the lock. He can send keys to others. Meanwhile he can increase the key management that is about to expire.

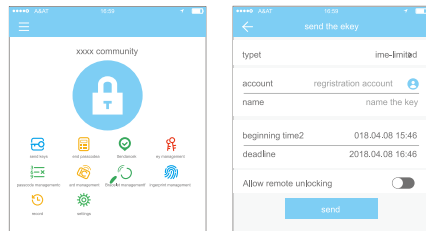

Click the type of lock it will show the time-limited ekey, one-time ekey and permanent ekey.

Time-limited ekey: The ekey is valid for the specified time

Permanent ekey: The ekey can be used permanently.

One-time ekey: the ekey will be automatically deleted once it has been used.

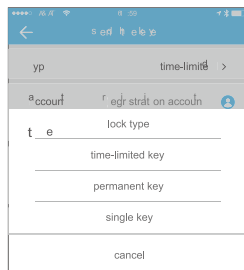

3.1 Key management

The manager can delete ekey, reset ekey, send and adjust the ekey, meanwhile he can search the lock record.

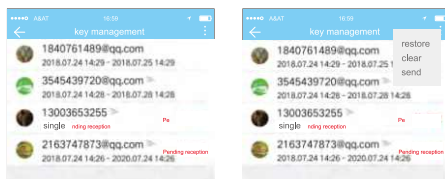

3.2 Deadline warning

System will show two colors for deadline warning. The yellow means close to expiring and the red means it has expired.

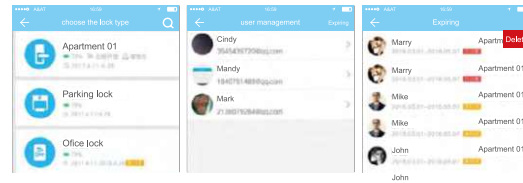

3.3 Search lock record

The administrator can query the unlock record of each key.

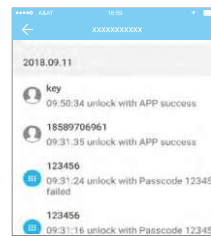

4. Passcode management

After inputting the passcode on the keyboard of the lock, press the unlock button to unlock. Passcodes are classified into permanent, time-limited, one-time, empty, loop, custom, etc.

4.1 Permanent passcode

The permanent passcode must be used within 24 hours after it is generated, otherwise it will automatically expire.

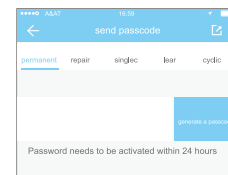

4.2 Time-limited passcode

The time-limited passcode can own an expiration date, which is a minimum of one hour and a maximum of three years.

If the validity period is within one year, the time can be accurate to the hour; if the validity period is more than one year, the accuracy is month.

When the time-limited passcode is valid, it should be used within 24 hours, otherwise, it will automatically expire.

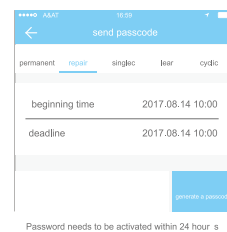

4.3 One-time passcode

One-time passcode can only be used for one time, and which is available for 6 hours.

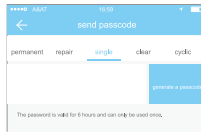

4.4 Clear code

Clear code is used to delete all the passcodes the lock has set, and which is available for 24 hours.



4.5 Cyclic passcode

The cyclic password can be reused within a specified time period, including daily type, weekday type, weekend type and more.

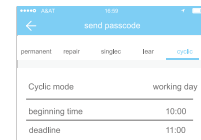

4.6 Custom passcode

User can set any passcodes and validity period he wants.

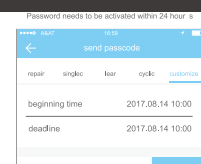

4.7 Passcode sharing

The system add new communication ways of Facebook Messenger and Whatsapp to help users share the passcode.

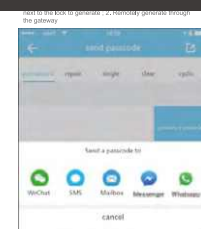

4.8 Passcode management

All generated passcodes can be viewed and managed in the password management module. This includes the right of changing the password, deleting the password, resetting the password, and unlocking the password.

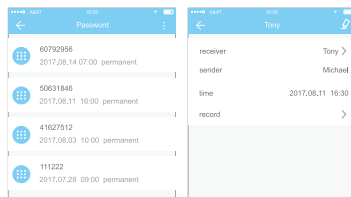

5. Card management

You need to add the IC card first. The whole process needs to be done via the app beside the lock. The validity period of the IC card can be set, either permanent or time-limited.

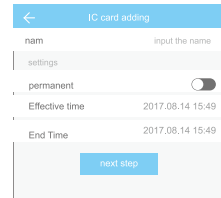

All IC cards can be queried and managed through the IC card management module. The remote card issuance function is displayed in the case of a gateway. If there is no gateway, the item is hidden.

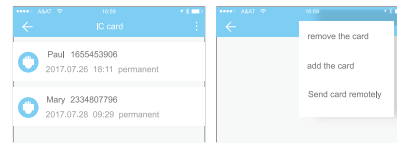

6. Fingerprint management

Fingerprint management is similar to IC card management. After adding a ingerprint, you can use the ingerprint to unlock the door.

7. Unlock via Bluetooth

App User can lock the door via Bluetooth and also can send the Bluetooth ekey to anyone.

•Unlock by APP

Click the round button at the top of the page to unlock the door. Since the Bluetooth signal has a certain coverage, please use the APP within the certain area.

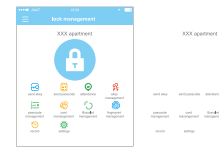

8. Passage mode

In the main interface of the app, select the passage mode in the settings, and the date of the passage mode can be set, and the start time and end time of the passage mode can also be set.

After the passage mode is activated, everyone can directly unlock the door without any access permission. The passage mode can be turned off by clicking again.

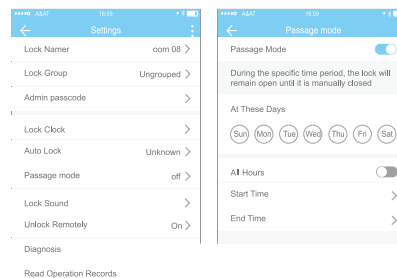

9. Attendance management

The APP is access control, which can be used for company attendance management. The app contains functions of employee management, attendance statistics and so on.

All 3.0 door locks have attendance functions. The normal door lock attendance function is turned off by default. The user can turn it on or off in the lock settings.

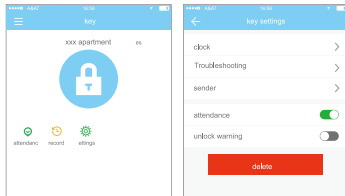

Attendance Statistics:

You can check the daily attendance of all staff. And the records can be sorted according to the time clocked. Late, leave early and no clock-in can be identified in three different colors.

Check Attendance:

Select an employee to check the attendance of the employee for each month. Slide left and right to switch months. At the bottom of the page, there is the statistics of the number of late, leave early, and no clock in this month.

Set Attribute:

The attendance function has a number of attributes that can be set, including company name, department, working hours, workdays, and holidays.

9.1 Attendance setting

Working Hours Setting:

Set the time of on or off duty. Judging late and leave early is based on these two data.

Workdays Setting:

Set which days of the week are workdays. There are two ways to set it up: customization and one-two-day weekend. Customization means that you can optionally set which days of the week are workdays. One-two-day weekend means that one-day weekend and two-day weekend rotate weekly.

Holidays Setting:

Set which days in the year are holidays. For example, one workday was set to be a holiday, if you do not clock in that day, it will not be treated as no clock in.

10. System setting

In the system settings, it includes touch unlock switch, group management, gateway management, security settings, reminder, transfer smart lock and so on.

Touch unlock setting determines whether you can open the door by touching the lock.

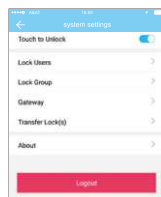

10.1 User management

The user name and phone number can be seen in the user list.

Click the customer you want to view to get the door lock information.

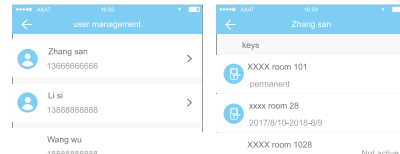

10.2 Key groups management

In the case of a large number of keys, you can use group management module.

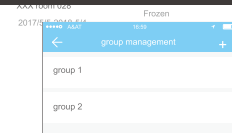

10.3 Transfer admin rights

The administrator can transfer the lock to other users or to the apartment (Room Master user). Only the account that manages the lock has the right to transfer the lock.

After inputting the account, you will receive a verification code. Filling in the correct number, you will transfer successfully. The account of the apartment transfer receive must be the administrator account.

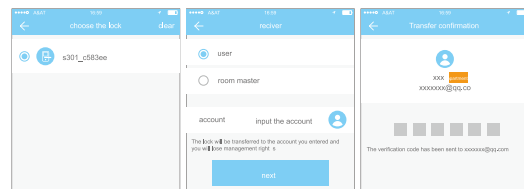

10.4 Lock recycling station

If the lock is damaged and cannot be deleted, the lock can be deleted by moving it into the recycling station.

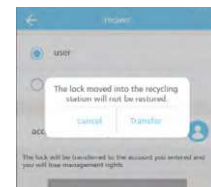

10.5 Customer service

The user can consult and give feedback through the AI customer service

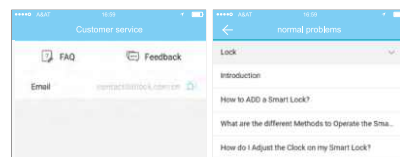

10.6 About

In this module you can check the app version number.